

# Lindab **Regula Combi 1.5**

## Program and operation modes

# Program/operation modes Regula Combi 1.5

## Content

Description.....	3
Regula Secura.....	3
Regula Connect Basic, Multi and Pascal .....	3
Program descriptions .....	3
1. Water .....	3
2. VAV .....	5
3. eHybrid .....	6
4. Change Over digital .....	6
5. Change Over sensor .....	7
6. Pascal VAV Supply (SRC) .....	8
7. Pascal VAV extract (ERC).....	10
8. Pascal VAV water (SRC).....	11
Operating mode .....	12
Operating mode Off .....	12
Operating mode Unoccupied .....	12
Operating mode Standby .....	12
Operating mode Occupied .....	12
Operating mode Bypass.....	12
CO <sub>2</sub> Sequence .....	13
Occupancy button .....	13
Presence detector.....	13
Condensation detector .....	13
Window contact .....	13
Electrical wiring diagram .....	14

# Program/operation modes Regula Combi 1.5

## Description

Regula Combi is a zone controller for integrated installation in products or directly on the wall. Regula Combi has a built-in temperature sensor and can use input from presence sensor, CO<sub>2</sub> sensor, condensation detector and an external temperature sensor (for Change Over systems).

For thermal on/off actuators Regula Combi controls digitally with time proportional pulses. By pulsing, the opening degree of the actuator (and its valve) is varied.

The period time (60s) is the sum of the on and off output times on the output.

The controller varies the on and off output times proportionally depending on the output signal demand to the actuator. Alternatively 0 - 10 V output can be chosen. A maximum of 10 actuators can be connected to the same controller.

Through its three outputs, Regula Combi can control only heating and/or cooling, as well as heating, cooling and forced cooling in sequence.

The controller has four inputs. One for presence sensor, one for CO<sub>2</sub> (0 - 10 V), one for condensation detector and one for an external temperature sensor (PT1000).

Regula Combi has 8 predefined programs which can be selected in the Service menu in the display.

The temperature setpoint value can be adjusted up and down from the basic set point values via the display (default +/-3°C) in steps of 0.5°C.

On cooling demand it will control according to the cooling set point, and on heating demand it will control according to the heating set point.

The set point change takes place halfway between the set points with a hysteresis of 0.1°C.

Regula Combi can also be set to operate Change Over systems, where the change over happens either via a digital signal or via an external temperature sensor in the heating/cooling media.

The display has indications for heating/cooling state, actual temperature and set point temperature when pressing increase/decrease buttons, and icons for the operating modes.

## Regula Secura

### Function

Regula Secura is a condensation guard for both chilled beams and facade systems, which works together with electronic control systems such as Regula Combi or any other equipment with thermoelectric actuators.

If there is condensation on the supply pipe, Regula Secura's humidity sensor gives a signal that cuts the power to the cooling.

## Regula Connect Basic, Multi and Pascal

### Function

Regula Connect Basic and Multi are two connection cards that provides flexible connection for chilled beams or facade systems. Regula Connect Basic and Multi consists of a connection card with connectors for main cables, thermostat cables and terminal blocks for actuator cables. Regula Connect Multi also offer connectors for CO<sub>2</sub>, RH and presence sensors plus a damper output for air flow regulation.

For further informations on the Regula connect Pascal, please see the Lindab [Pascal documents](#).

## Program descriptions

### 1. Water

The regulation of temperature takes place in sequences with heating, cooling and forced (cooling) ventilation by signals from the universal outputs UO1 (heating), UO2 (cooling).

The proportional part of the temperature regulation is shown diagram 1. Set points are adjustable.

The universal outputs for UO1 and UO2 are default set to thermal on/off actuators. Heating and cooling actuators (UO1 and UO2) are exercised every 23 h.

The universal output UO3 (forced cooling ventilation) will be activated with 100% signal by pressing the Occupancy button (Bypass operating mode).

Bypass will also occur if:

- The UO2 cooling has reached 100% (this can be deactivated by changing P76).
- Time delay for leaving Bypass mode, when Cooling is getting lower than 100%, is set as Disconnect timer in P13 (default 30 min.).
- Connecting a CO<sub>2</sub> sensor to AI2 and configuring it (P81 = 5), which will activate Bypass if CO<sub>2</sub> level is more than the set level in P97 (default 800 ppm).
- Deactivation happens at the set value in P97 minus the set hysteresis value in P98 (default 160 ppm). Time delay for leaving Bypass mode is set in P12 (default 45 min.).

Operating mode Standby occurs after 30 min (adjustable) if a presence sensor is connected and signal is given, then the temperature will be regulated against standby temperature setpoints, 20°C and 24°C (both adjustable).

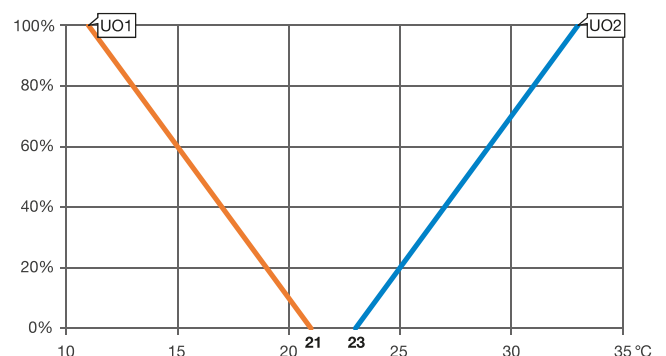

Diagram 1.

# Program/operation modes Regula Combi 1.5

## Water program variants

### a) Water Heating/Cooling and separate VAV forced Cooling

Parameter changes:

P11 to value 8 = Heating/Cooling/VAV.

UO3 is default 0-10V but with Min flow at Y3 output P48 = 20 %, so the signal is 2 - 10V.

If UO3 ascends to 100 % signal, Bypass operating mode will be activated for 45 min (adjustable). Bypass can also be activated by pressing the Occupancy button once.

Off mode will result in 0% signal and thus closing the damper.

If connecting a CO<sub>2</sub> sensor (CTRTA-D-LB or another 0 - 10 V modulating CO<sub>2</sub> sensor) then activate the analogue input AI2 by changing P81 to value 5 = CO<sub>2</sub>-sensor.

UO3 will be affected according to the CO<sub>2</sub> sequence. CO<sub>2</sub> levels are set with P112 and P113.

The major requirement from the second part of the cooling sequence and the CO<sub>2</sub> sequence will control the UO3 signal.

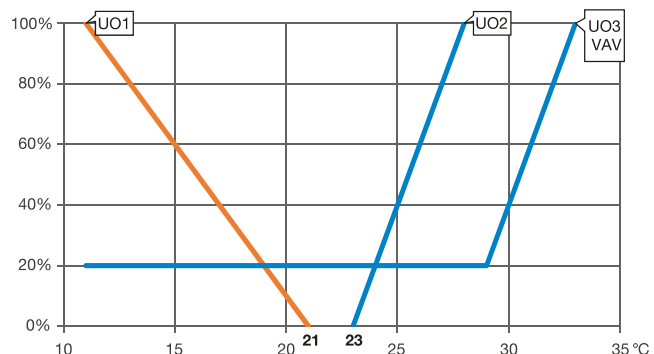

Diagram 1a.

### b) Water Heating/Cooling and separate on/off damper

Parameter changes:

P22 to value 1 = Forced vent.

Digital, P45 to value 3 = Occupied and P77 to 4 = Bypass.

At Bypass UO3 will open the on/off damper with 24V AC. (Note that Neutral and Load on the on/off damper must be switched). Bypass can also be activated by pressing the Occupancy button once.

### c) Water Heating/Cooling with VAV as first Cooling sequence

Parameter changes:

P11 to value 8 = Heating/Cooling/VAV,

P49 to the desired max UO3 output at heating e.g. 60% and P75 to 1 = Y3 activates before Y2.

With a VAV damper mounted on the supply duct to an active chilled beam, it is recommendable to have VAV as the first cooling sequence.

The VAV damper could also be on a separate duct.

UO3 is default 0 - 10 V

but with Min flow at Y3 output P48 = 20%, so the signal is 2 - 10 V.

When there is heating on UO1, the VAV output UO3 will follow the UO1 signal to the desired max output at heating, e.g. 60%.

If UO3 ascends to 100% signal, Bypass operating mode will be activated for 45 min (adjustable).

Bypass can also be activated by pressing the Occupancy button once. Off mode will result in 0 % signal and thus closing the damper.

If connecting a CO<sub>2</sub> sensor (e.g. CTRTA-D-LB) then activate the analogue input AI2 by changing P81 to value 5 = CO<sub>2</sub>-sensor.

UO3 will be affected according to the CO<sub>2</sub> sequence. CO<sub>2</sub> levels are set with P112 and P113. The major requirement from the second part of the cooling sequence and the CO<sub>2</sub> sequence will control the UO3 signal.

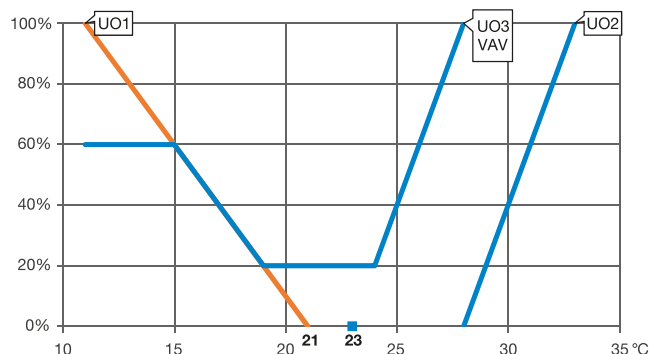

Diagram 1c.

# Program/operation modes Regula Combi 1.5

## 2. VAV

The regulation of temperature takes place in sequences with heating and cooling by signals from the universal outputs UO1 (heating) and UO2 (cooling).

The proportional part of the temperature regulation is shown in diagram 2. Set points are adjustable.

The universal outputs UO2 and UO3 will be activated with 100% signal by pressing the Occupancy button (Bypass operating mode) for 45 min (can be changed in Parameter 12).

The universal outputs for UO1, UO2 and UO3 are default set to 0 - 10V. Heating and cooling actuators (UO1 and UO2) are exercised every 23 h.

The min flow at cool output (UO2) is set to 20% (default), so the cooling sequence will result in signals from 20 - 100%.

By pressing the Occupancy button for more than 5 seconds operating mode Off will occur, that will change the UO2 signal to 0% regardless of cooling or heating demands.

This match Lindab volume flow regulator functions.

Operating mode Standby occurs after 30 min (adjustable) if a presence sensor is connected and signal is given, then the temperature will be regulated against standby temperature setpoints, 20°C and 24°C (both adjustable).

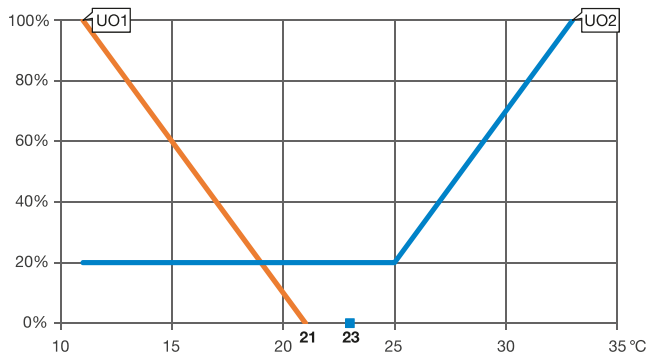

Diagram 2.

### VAV program variants

#### a) VAV with CO<sub>2</sub> sensor

Parameter changes:  
P81 to value 5 = CO<sub>2</sub>-sensor.

When connecting a CO<sub>2</sub> sensor (e.g. CTRTA-D-LB) activation of the analogue input AI2 is needed.

Both UO2 and UO3 will be affected according to the CO<sub>2</sub> sequence. CO<sub>2</sub> levels are set with P112 and P113.

The major requirement from the cooling sequence and the CO<sub>2</sub> sequence will control the UO2 signal.

#### b) VAV with air duct heating

Parameter changes:  
P49 to the desired max UO2 output at heating e.g. 60%.

This will activate a heating function for UO2.

It will allow UO2 to follow the heating signal UO1 to a free chosen max level (P49) when there is heating demand.

This should only be used when having heated air (above room temperature) in the duct by connecting UO1 to a duct heater.

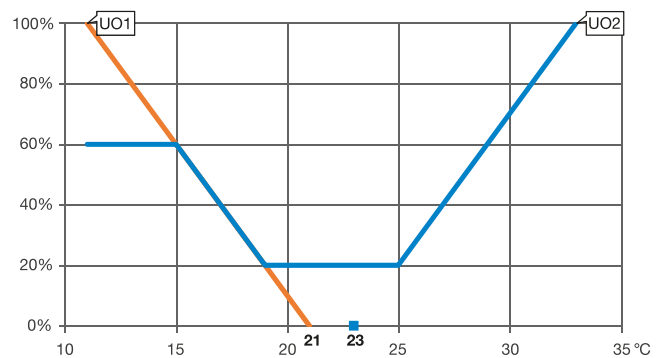

Diagram 2b.

#### c) RCW-1 blade control

Parameter changes:  
P1 to value 15 C, P2 to value 16°C, P7 to value 12°C, P8 to value 0s and P15 to value 1 = External sensor.

(P2 is used to set the lowest temperature, however P1 must always be set to a value lower than P2).

Regula Combi can control the RCW-1 blade angles when connecting the 2-10 V modulating motor to UO2.

A duct sensor (TG-K3/PT1000 or TG-KH/PT1000) must be mounted in the supply duct and connected to the analogue input AI1.

The blade angles will then be controlled according to diagram 2c.

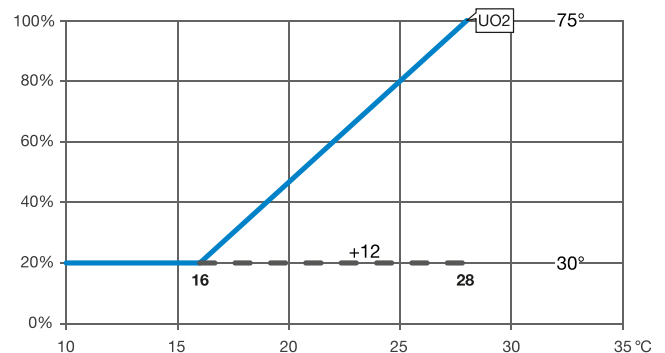

Diagram 2c.

# Program/operation modes Regula Combi 1.5

### 3. eHybrid

The regulation of temperature takes place in sequences with heating and cooling by signals from the universal outputs UO1 (heating) and UO2 (cooling).

The sequence of UO3 is depending on whether there is occupancy or not. At operating mode Occupied UO3 = 100%.

At Standby UO3 is following the cooling signal UO2 and the heating signal UO1 to a changeable max limit (default is 60%, so as default the UO3 damper will stay half open at full heating demand).

See the proportional part of the temperature regulation sequences in the diagrams. Set points are adjustable.

The universal outputs for UO1 and UO2 are default set to thermal on/off actuators.

UO3 is default set to 0 - 10V. Heating and cooling actuators (UO1 and UO2) are exercised every 23 h.

Operating mode Standby occurs after 20 min (adjustable) if a presence sensor is connected and signal is given, then the temperature will be regulated against standby temperature setpoints, 20°C and 24°C (both adjustable).

### 4. Change Over digital

Change-over is a function, which makes it possible to use the same pipe/duct for both heating and cooling, depending on requirements during for example summer (cooling output) and winter (heating output).

Sequences for temperature, CO<sub>2</sub> and occupancy functions are as Program 1 Water, though universal outputs for UO1, UO2 and UO3 are default set to 0 - 10 V.

UO1 and UO2 will act alike with same output level.

At Bypass mode, only UO3 will go to 100% output signal.

When using the digital signal input DI2 (potential-free contact), closing the contact switches the change-over function and sets the output UO1 to cooling sequence.

On open contact, the change-over function sets the output UO1 to heating.

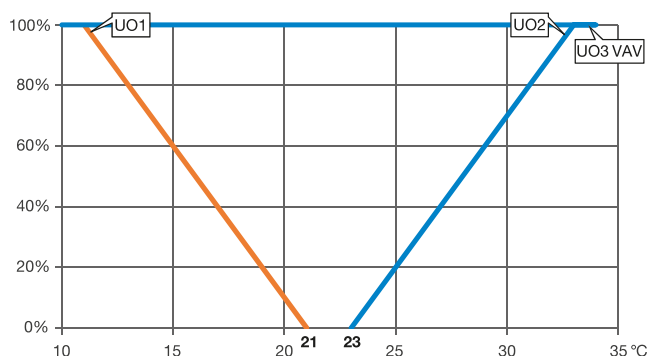

Diagram 3 (Occupied).

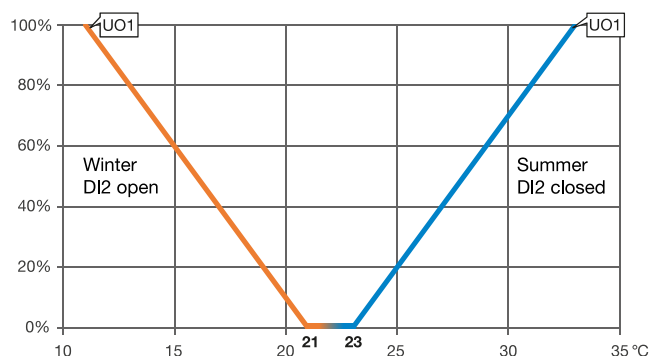

Diagram 4.

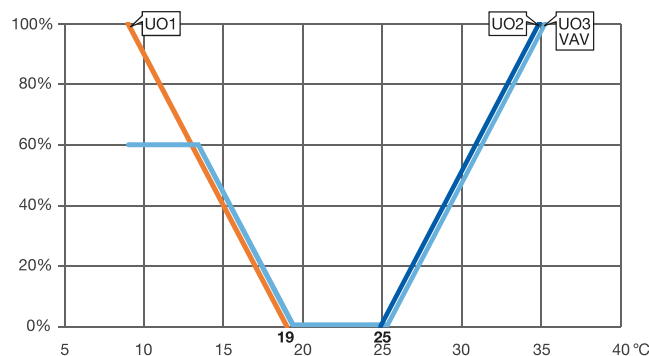

Diagram 3 (Standby).

# Program/operation modes Regula Combi 1.5

## 5. Change Over sensor

Change-over is a function, which makes it possible to use the same pipe/duct for both heating and cooling, depending on requirements during for example summer (cooling output) and winter (heating output).

Sequences for temperature, CO<sub>2</sub> and occupancy functions are as Program 1 Water, though universal outputs for UO1, UO2 and UO3 are default set to 0-10 V.

UO1 and UO2 will act alike with same output level.

At Bypass mode, only UO3 will go to 100% output signal.

A sensor (PT1000) must be connected to the analogue input AI1.

The Pt1000-sensor connected to AI1 must be mounted so that it senses the temperature in/on the heating/cooling media.

The change-over function will measure the difference between the room and media temperature.

As long as the heat valve is more than 20% open, or every time a valve exercise is performed, the difference between the media and room temperature will be calculated.

If the temperature difference is lower than the configured value (differs for Heating and Cooling mode), the control mode will change.

The default settings for the difference between Heating and Cooling change-over are 3K (P9) and 4K (P10) respectively.

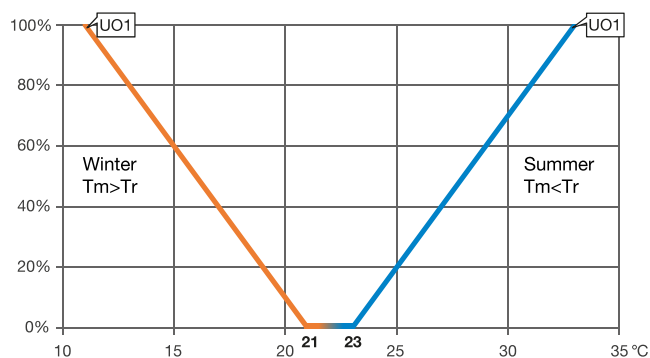

Diagram 5.

# Program/operation modes Regula Combi 1.5

## 6. Pascal VAV Supply (SRC)

The regulation of temperature takes place in sequences with heating and cooling by signals from the universal outputs UO1 (heating) and UO2 (cooling), and the volume flow regulator (MBV/DBV or FTCU/VRU) must be connected to the cooling output.

Heating output UO1 is exercised every 23 h (P36). Cooling output UO2 is exercised every 23 h (P37) for 30 s, i.e. opening (10 V) for 15 s and closing (2,5 V) for 15 s (P34).

For easy commissioning all air flow settings for ventilation in the room are set in Regula Combi (and not in the volume flow regulator).

The cooling part of the temperature sequence will then result in variable output signals, which depend on four different air flow settings:

Minimum air flow at presence/occupied (*AirflowMinOcc*).

Maximum air flow at presence/occupied (*AirflowMaxOcc*).

Standby air flow (*AirflowStandby*) when there is no presence, and a size dependable air flow (*AirflowNominal*).

Normally *AirflowNominal* should not be changed manually.

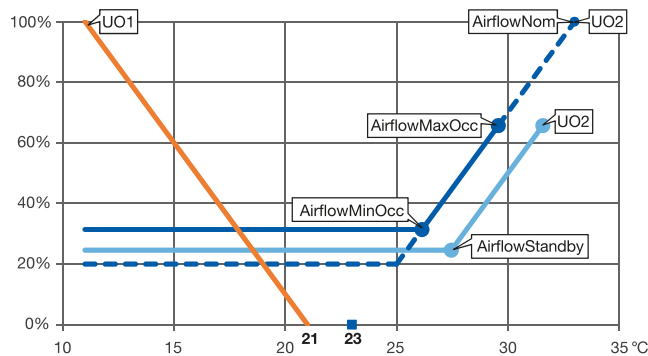

Diagram 6.

A CO<sub>2</sub> sensor with modulating 0 - 10 V output (e.g. CTRTA-D-LB or CTD2) can be used in Pascal together with Regula Pulse, if actual CO<sub>2</sub> values are to be registered in a top level system via Regula Combi (SRC).

CTRTA-D-LB must be connected to Regula Combi via Regula Pulse, which transforms the 0 - 10 V signal into digital pulses read by DI2 in Regula Combi (through Regula Connect Pascal).

Damper position is registered in Regula Combi as a 2 - 10 V (DC) signal through AI2, and via EXOline it is used in Regula Master for fan optimization.

Also the air flow set point from Regula Combi is collected in Regula Master (via EXOline) and is used for extract regulation.

In program 6 the modes Off, Unoccupied, Standby, Occupied and Bypass are used.

The preset operating mode can be set to Standby or Occupied (default Occupied).

Off can be reached by pressing the occupancy button for more than 5 sec. This will close the volume flow regulator damper (with 0V).

In mode Unoccupied Regula Combi will use the setpoints Heating setpoint at Unoccupied (default 15°C) and cooling setpoint at Unoccupied (default 30°C).

Any setpoint displacement is not active in Unoccupied mode. So if the actual temperature is lower than cooling setpoint at Unoccupied (default 30°C) AirflowMinOcc is transmitted from the cooling output.

By connecting a presence detector to Regula Combi at DI1 and C+, Standby will occur if there is no presence in the room.

Requirement for Standby function is that the preset operating mode must be set to Standby and DI1 to Normally Open (P60 = 0).

When Standby is active a signal corresponding to the air flow setting AirflowStandby will be transmitted from the cooling output, however if the room temperature exceeds the standby cooling setpoint set in P306 (default 24°C) + setpoint displacement + Neutral zone at Standby (default 2°), the cooling output will vary between AirflowStandby and AirflowMaxOcc.

If no presence detector is connected or if the presence detector indicates presence, mode Occupied will occur.

In Occupied mode cooling output will vary between AirflowMinOcc and AirflowMaxOcc.

Bypass can be reached by pressing the occupancy button, and a signal corresponding to AirflowMaxOcc will be transmitted from the cooling output UO2.

The mode (state) of a SRC can be changed from Regula Master and by EXOline / Modbus commands via Regula Master.

# Program/operation modes Regula Combi 1.5

All air flows are set in the Service parameter menu (in l/s).

Product	System	Size of damper	Size	Airflow Standby MBV/DBV/LCFV (0.4 m/s; 2.46 V) FTCU/VRU (0.7 m/s; 2.80 V)	Airflow MinOcc (1 m/s; 3.14 V)	Airflow MaxOcc (4 m/s; 6.57 V)	Airflow Nominal (7 m/s; 10 V)
Other	Supply / Extract	0	Unknown	0.01	0.01	0.01	0.01
MBV / DBV / LCFV	Supply	3	125	5	12	49	86
MBV / LCFV	Supply	4	160	8	20	80	141
MBV / LCFV	Supply	5	200	13	31	126	220
MBV	Supply	6	250	20	49	196	344
MBV	Supply	7	315	31	78	312	546
FTCU / VRU	Supply / Extract	22	100	5	8	31	55
FTCU / VRU	Supply / Extract	23	125	9	12	49	86
FTCU / VRU	Supply / Extract	24	160	14	20	80	141
FTCU / VRU	Supply / Extract	25	200	22	31	126	220
FTCU / VRU	Supply / Extract	26	250	34	49	196	344
FTCU / VRU	Supply / Extract	27	315	55	78	312	546
FTCU / VRU	Supply / Extract	28	400	88	126	503	880
FTCU / VRU	Supply / Extract	29	500	137	196	785	1374
FTCU / VRU	Supply / Extract	30	630	218	312	1247	2182

Table 1: Default values for Airflows. Note! Flow per MBV/DBV/LCFV, FTCU/VRU.

**Note:** If more than one volume flow regulator is controlled by the same Regula Combi, the size of the volume flow regulators must be the same. Every volume flow regulator size has predefined default values for AirflowNominal, AirflowMaxOcc, AirflowMinOcc and AirflowStandby. These values can of course be changed, but are reset to default values if the parameter for size is changed.

## Pascal VAV supply program variants

### a) Pascal VAV supply and CO<sub>2</sub> Pulse sensor

Parameter changes:

P18 to value 6 = CO<sub>2</sub> Pulse sensor.

If actual CO<sub>2</sub> values are to be registered in a top level system then a Regula Pulse together with the modulating CO<sub>2</sub> sensor (e.g. CTRTA-D-LB or CTD2) has to be connected to Regula Combi via Regula Connect Pascal.

More Regula Pulse sensors must not be parallel connected with linked Regula Connect Pascal cards.

Actual CO<sub>2</sub> values will be registered in steps of 5 ppm.

### b) Pascal VAV supply with air duct heating

Parameter changes:

P49 to the desired max UO2 output at heating e.g. 60%.

This will activate a heating function for UO2. It will allow UO2 to follow the heating signal UO1 to a free chosen max level (P49) when there is heating demand.

The set percentage will correspond to the set AirflowMinOcc (0%) and AirflowMaxOcc (100%).

This should only be used when having heated air (above room temperature) in the duct by connecting UO1 to a duct heater.

When the heating function on UO2 is activated, forced cooling ventilation (Bypass) by pressing the Occupancy button will lead to AirflowMaxOcc on UO2.

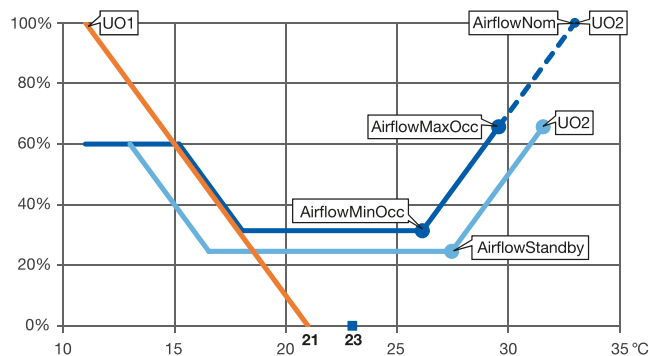

Diagram 6b.

### c) Pascal VAV supply with Change Over digital

Parameter changes:

P18 to value 4 = Change-over sensor. (This will automatically also change P11 to value 2 = Heating or Cooling via change-over).

Then it is possible to use Pascal for a change over system, where the same duct for both heating and cooling is used, depending on requirements during for example summer (Cooling) and winter (Heating).

When using the digital signal input DI2 (potential-free contact), closing the contact switches the change-over function and sets the output UO2 to Heating sequence. On open contact, the change-over function sets the output UO1 to Cooling. Sequences are shown in the diagram.

# Program/operation modes Regula Combi 1.5

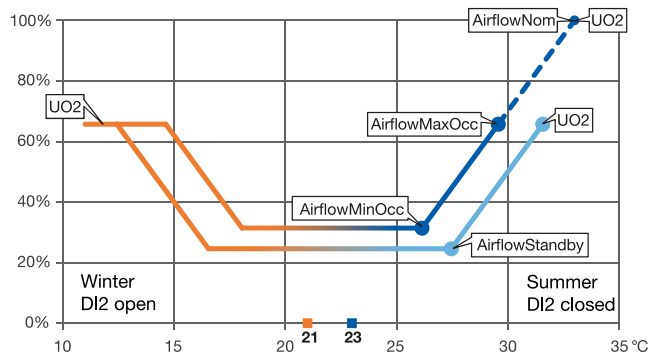

Diagram 6c.

### d) Pascal VAV supply with Change Over sensor

Parameter changes:

P15 to value 2 = Change-over sensor.

Then it is possible to use Pascal for a change over system, where the same duct for both heating and cooling is used, depending on requirements during for example summer (Cooling) and winter (Heating).

A duct sensor (e.g. TG-K3/PT1000 or TG-KH/PT1000) must be mounted in the supply duct and connected to the analogue input AI1.

The sensor must be able to sense the supply temperature in the duct.

The change-over function will measure the difference between the room and supply temperature.

As long as the damper is more than 20% open, or every time an exercise is performed, the difference between the supply temperature and room temperature will be calculated.

If the temperature difference is lower than the configured value (differs for Heating and Cooling mode), the control mode will change.

The default settings for the difference between Heating and Cooling change-over are 3K (P9) and 4K (P10) respectively.

Sequences are shown in the diagram.

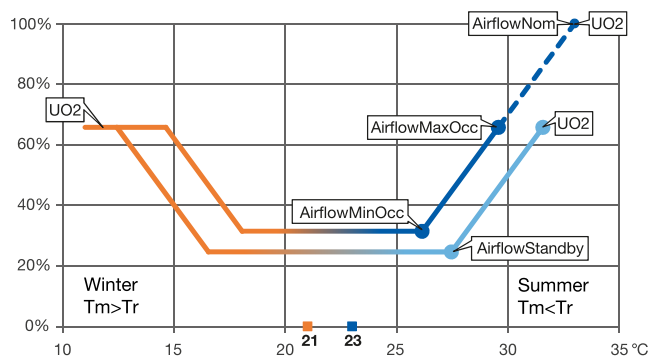

Diagram 6d.

### 7. Pascal VAV extract (ERC)

The Pascal VAV extract program is quite simple, since there is no regulation of room temperature.

This program simply collects the extract air flow value sent by Regula Master via EXOline and translates it to a corresponding 2 - 10 V air flow control signal for the extract volume flow regulator at UO2.

In program 7 there is no temperature regulation.

The controller serves as a translator for the extract flow signal that is sent from Regula Master (via EXOline).

The extract flow signal is converted and transmitted to the cooling output depending on number of dampers (P138) and the chosen volume flow regulator size (P139).

Every volume flow regulator size has predefined default values for AirflowNominal (P143).

This value can be changed, but is reset to default value if the parameter for size is changed.

The extract damper position is registered (via EXOline) and used in Regula Master for fan optimization.

# Program/operation modes Regula Combi 1.5

## 8. Pascal VAV water (SRC)

The Pascal VAV water program is identical with program 6 but with the cooling sequence split in two, with the first half (UO2) for VAV and the second half (UO3) for cooling actuator.

The program is designed to make it possible to combine Pascal VAV functionality with an active chilled beam, and making sure that there will be full (max) air flow on the active chilled beam before the cooling water is active.

The cooling actuator for the chilled beam on UO3 is 0 - 10 V as default.

The proportional part of the temperature regulation is shown in diagram 8.

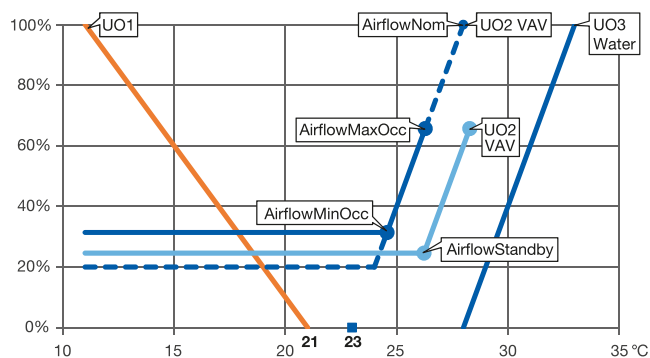

Diagram 8.

## Pascal VAV water program variants

### a) Pascal VAV water with heating actuators in beam

If there is heating in the (chilled) beam, it can be necessary to increase the air flow to the beam at heating need.

Parameter changes: P49 to the desired max UO2 output at heating e.g. 60%.

This will activate a heating function for UO2.

It will allow UO2 to follow the heating signal UO1 to a free chosen max level (P49) when there is heating demand.

The set percentage will correspond to the set AirflowMinOcc (0%) and AirflowMaxOcc (100%).

This function should only be used when having heating coil in the active chilled beam and connecting UO1 to the heating actuator.

When the heating function on UO2 is activated, forced cooling ventilation (Bypass) by pressing the Occupancy button will lead to AirflowMaxOcc on UO2.

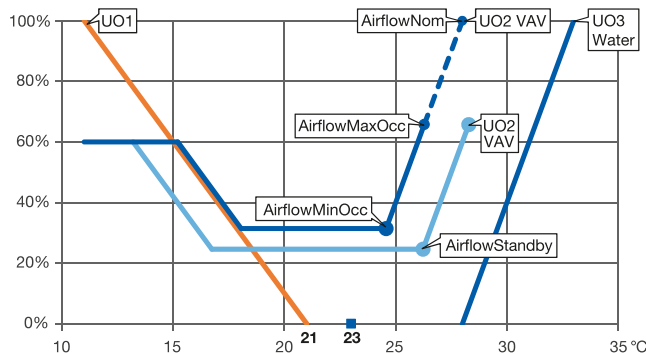

Diagram 8b.

# Program/operation modes Regula Combi 1.5

## Operating mode

Regula Combi is based on Regin Regio Midi RC-CDOC which has five different operating modes:

Off, Unoccupied, Standby, Occupied and Bypass.

### Operating mode Off

Operating mode off means that the controller is not heating or cooling.

However, the temperature must not drop below a set minimum temperature (8°C). If it does, the controller will start heating.

In the display the background lighting is not lit, and only OFF is shown in the display. (Off can be reached by pressing the Occupancy button for more than 5 seconds).

### Operating mode Unoccupied

Operating mode Unoccupied means that the room where the controller is placed is not used for an extended period of time, for example during holidays or long weekends.

Both heating and cooling are deactivated within a temperature interval with configurable min/max temperatures (default min = 15°C, max = 30°C).

In the display the background lighting is not lit, but the current room temperature (or setpoint depending on the configuration) is shown in the display.

OFF is also shown in the display.

### Operating mode Standby

Operating mode Standby means that the room is in energy save mode.

The controller is prepared to change operating mode to Occupied (comfort) if someone enters the room (presence). As default the room temperature is controlled around the standby heating and cooling set points (default 20°C and 24°C, P305 and P306).

Alternatively by changing P304, the room temperature will be controlled around the basic temperature setpoints (default 21°C and 23°C, P1 and P2) with an extended temperature interval (default +/-2°C, P3).

In the display the background lighting is lit (dimmed). STANDBY and the current room temperature (or set point depending on the configuration) are shown in the display.

In programs (1 - 5) with Standby as default the digital input DI1 for presence sensor is set default to NC (normally closed) in Regula Combi, so the controller will immediately change to Occupied if no presence sensor is connected or if the presence sensor indicates occupancy.

### Operating mode Occupied

Operating mode Occupied means that the room is in use and is therefore in a comfort mode.

The controller regulates the room temperature around the heating set point (default 21°C) and the cooling setpoint (default 23°C).

The set points can be adjusted +/- 3°C locally with the increase/decrease buttons.

In the display the background lighting is lit (dimmed), and the occupancy indication is shown (see Display handling and indications).

The current room temperature (or set point depending on the configuration) is also shown in the display.

### Operating mode Bypass

Operating mode Bypass means that the controller controls the room temperature in the same way as in operating mode Occupied, but the output for forced ventilation is active with full signal (100%).

After a configurable time (default 45 min) in Bypass, the controller automatically returns to the preset operating mode.

Bypass is activated when the Occupancy button is pressed once (for less than 5 sec), or if 100% cooling signal is needed (because of too high room temperature or CO<sub>2</sub> level).

The operating mode is useful for example in conference-rooms, where many people are present at the same time for a certain period of time.

In the display the background lighting is lit (dimmed). The occupancy indication and the symbol for forced ventilation are shown (see Display handling and indications).

The current room temperature (or setpoint depending on the configuration) is shown in the display.

# Program/operation modes Regula Combi 1.5

## CO<sub>2</sub> Sequence

A CO<sub>2</sub> sensor CTRTA-D-LB can be used as input for Regula Combi. The signal from the CO<sub>2</sub> sensor to the Regula Combi is 0 - 10 V corresponding to 0 - 2000 ppm.

In the Regula Combi a lower and upper limit of CO<sub>2</sub> is set (default 800 and 1000 ppm).

These limits will affect the output signal (UO2 or UO3) from Regula Combi. The CO<sub>2</sub> limits are adjustable (parameter 112 and 113).

### Output signal actuator/signal from CO<sub>2</sub> sensor

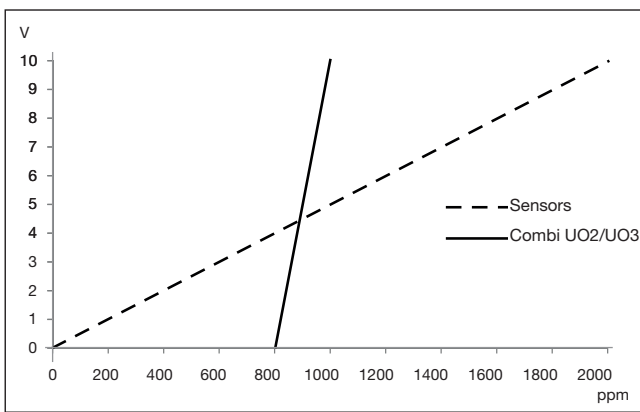

For programs 1 - 6, AI2 is used for the CO<sub>2</sub> 0 - 10 V modulating sensor.

In program 1 the CO<sub>2</sub> control of the damper can either be on/off or modulating depending on controller mode (P11).

For programs 6 and 8, the CO<sub>2</sub> 0 - 10V modulating sensor has to be connected to Regula Pulse, which then is connected to DI2. (See Pascal documentation for connection of Regula Pulse).

## Occupancy button

When pressing the occupancy button for less than 5 sec, the controller is set to forced ventilation (Bypass).

If the button is pressed again when forced ventilation is active, the controller will go to the Preset operating mode (default: Standby/Occupied).

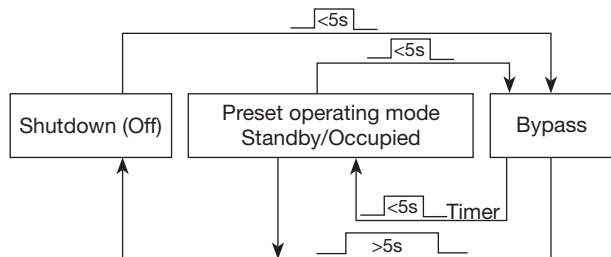

When the Occupancy button is held depressed for more than 5 seconds, the controller changes operating mode to Off, regardless of the current operating mode.

If you press the Occupancy button for less than 5 seconds when the controller is in Off, Standby or Occupied mode, the controller changes to Bypass mode.

If you press the button for less than 5 seconds when the controller is in Bypass mode, it changes operating mode to the Preset operating mode (default: Standby/Occupied).

After a configurable time in Bypass (default 45 min.), the controller returns to the preset operating mode (default: Standby/Occupied).

## Presence detector

For local control of the operating mode between the preset operating mode (Standby) and Occupied, a presence detector can be connected.

When presence is indicated, the controller changes operating mode to Occupied.

In Occupied, there is a switch-off timer, which means that if there is no presence indication during this time (default 30 min), the controller will return to the preset operating mode (Standby).

The off-delay must be at least 1 minute.

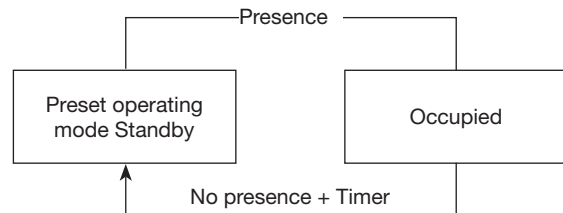

## Condensation detector

For programs 1 - 5 the digital input DI2 is as default configured for condensation sensor.

When condensation is detected, the signal from the room controller to the cooling actuator is blocked.

Lindab recommends using the condensation input only when the Regula Combi unit is integrated into the beam and thereby only one cooling actuator is controlled by the Regula Combi.

If the Regula Combi unit is placed on the wall Lindab recommends using the Regula Secura instead that not involves the special input (CI) on the Regula Combi.

## Window contact

If configuring DI1 or DI2 (via parameter 17 or 18) to a window contact, and the window is open,

RC will set cooling outputs to minimum and regulate the heating according to the frost protection setpoint set in parameter 6 (default 8°C).

# Program/operation modes Regula Combi 1.5

## Electrical wiring diagram

### Connection descriptions

The maximum number of actuators that can be connected to the digital output (ON/OFF) is 10 for cooling and heating, respectively.

When more than 4 on/off actuators for cooling or heating are connected, terminal blocks 10 and 20 must be connected with a cable because the Regula Combi print card can not handle the output power for more than 4 on/off actuators.

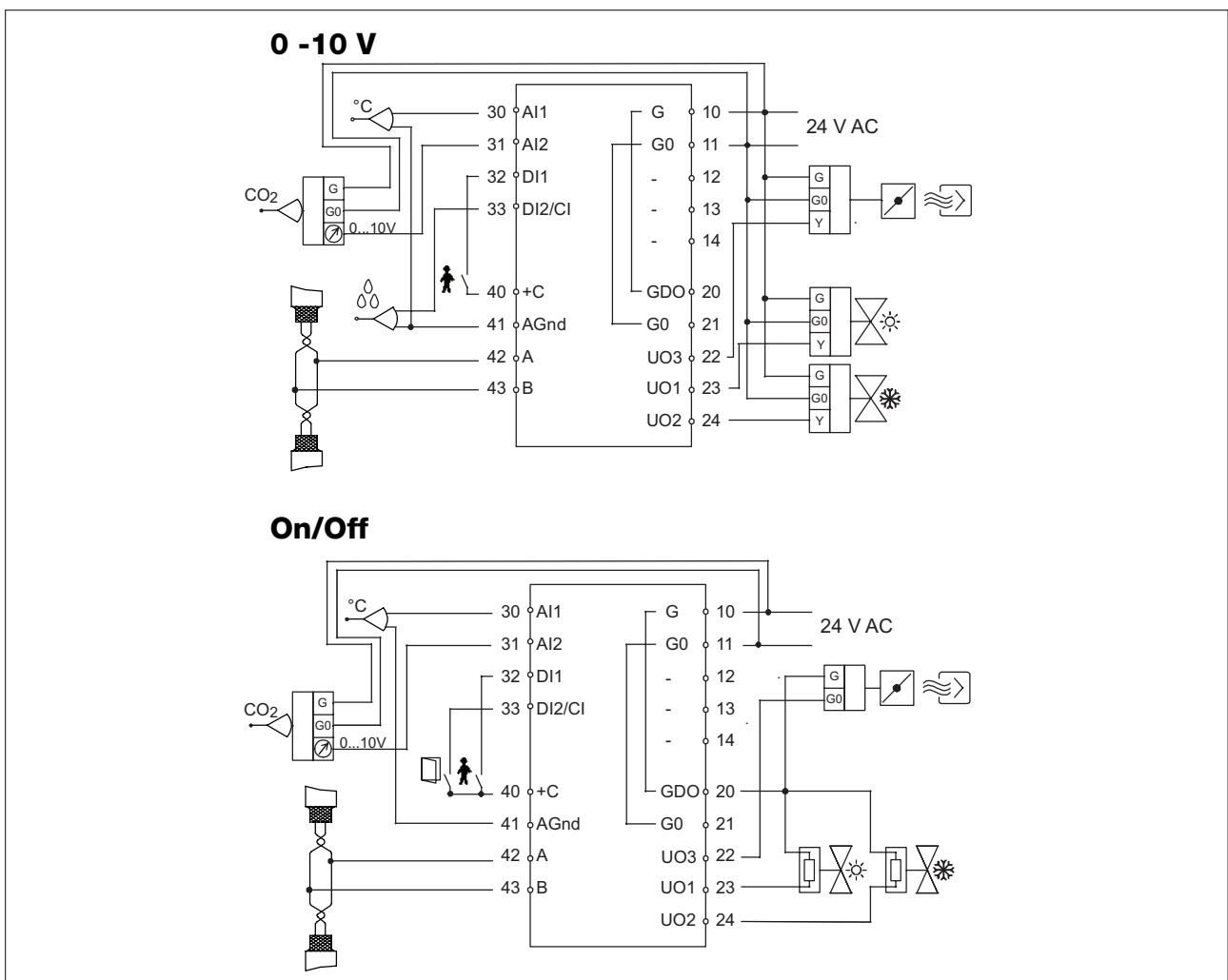



Most of us spend the majority of our time indoors. Indoor climate is crucial to how we feel, how productive we are and if we stay healthy.

We at Lindab have therefore made it our most important objective to contribute to an indoor climate that improves people's lives. We do this by developing energy-efficient ventilation solutions and durable building products. We also aim to contribute to a better climate for our planet by working in a way that is sustainable for both people and the environment.

[Lindab](#) | For a better climate